

GE Infrastructure Security

GE Security's popular XPosure technology, which produces detailed images even in challenging lighting conditions, is now available in a discreet dome camera. The economical UltraView Dome measures less than 5 inches across and is the best security solution for bright areas such as in front of glass doors and large windows.

The UltraView Dome's XPosure technology utilizes an advanced, next-generation sensor that makes every pixel its own camera. Using intelligent image processing, XPosure optimizes each pixel, capturing detail in shadows and managing bright glare and reflections. That's why it works so well to show details like facial features when positioned near business entrances and well-lit lobbies—places where other cameras do no better than silhouette a person or object.

Unlike other cameras—even wide dynamic range models—which require complex setup and calibration, the UltraView wide dynamic range dome works right out of the box. Simply plug it in, adjust the position and the included 4 to 9 mm varifocal lens, and use the camera.

Its rugged aluminum housing means the UltraView Dome can be used in a variety of applications. The bubble is constructed of extra-strong impact-resistant polycarbonate and is available in clear. Tamper-resistant screws are provided with all domes.

Several adapters are available to fit a variety of applications. These accessories make installation easy whether you wish to mount the UltraView Dome to a ceiling, wall, corner, or pole. A surface-mount adapter ships with each dome camera.

Features

- Utilizes GE XPosure technology to give clear images in less-than-ideal lighting conditions
- Measures less than 5 inches across—suitable for discreet applications
- Applications include building lobbies with large glass windows or doors, outdoor ATM machines, and other areas that receive direct sunlight
- Fast electronic shutter speed
- Heavy-duty, weather-resistant, aluminum housing
- Polycarbonate dome with optional tamper-resistant screws
- Works with 12 VDC or 24 VAC power

UltraView Dome

Wide dynamic range dome camera with XPosure technology





Specifications

Americas
503-885-5700
888-GE-SECURITY
(437-3287)
faxback 800-483-2495
info@gesecurity.com
www.gesecurity.com

Asia
tel 852-2907-8108
fax 852-2142-5063

Australia
tel 61-3-9259-4700
fax 61-3-9259-4799

Europe
tel 32-2-725-11-20
fax 32-2-721-86-13

Latin America
tel 305-593-4301
fax 305-267-4300

Camera

- Image sensor: 1/3 in. sensor with GE Xposure technology
- Dynamic range: 95 dB typ./120 dB max.
- Scanning system: 525/60 (NTSC); 625/50 (PAL)
- Synchronization: Internal / line-lock AC
- Pixels: 720 H x 540 V
- Resolution: 470 TVL horizontal/460 TVL vertical
- Sensitivity: 0.6 lux @ f1.2, 30 IRE
- Signal-to-noise ratio: 50 dB
- Automatic gain control: Max. 30 dB
- Gamma compensation: 0.45
- Lens: 4 to 9 mm varifocal

Electrical

- Input voltage: 12 VDC or 24 VAC
- Power: 12 VDC, 455 mA; 24 VAC, 160 mA

Physical

- Weight: 1.5 lb. (703 g)
- Construction, housing and adapters: Aluminum
- Construction, dome: 0.130 in (3.3 mm) polycarbonate (clear or smoke)
- Finish, housing: Powder coat

Environmental

- Operating temperature: 14 to 113°F (-10 to 45°C)

Regulatory

- FCC

Accessories

- Flush-mount adapter: KTA-FM-38
- Wall-mount adapter: KTA-WH-38
- Corner-mount bracket: KTA-CM-38
- Pole-mount bracket: KTA-PM-38
- Pendant-mount adapter: KTA-PH-38
- Conduit-mount adapter: KTA-CA-38

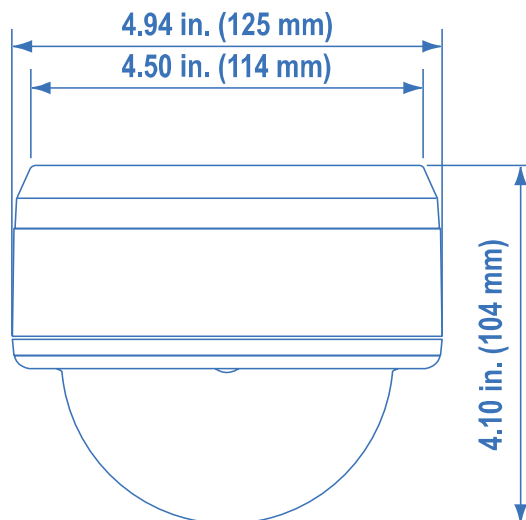

Ordering Information

DI-XP2-VF3 UltraView dome camera with Xposure technology, wide dynamic range