

www.GESecurity.com

KTD-400 Controller Keypad

Overview

The KTD-400 is a keypad that controls Digiplex® system components. It can address and manage 512 PTZ (pan/tilt/zoom) receiver sites, operate a matrix switcher with 64 monitor outputs, and address and select views from as many as 64 multiplexers. Its multispeed control feature allows users to toggle between slow, medium, and fast speed control for PTZ camera assemblies. The KTD-400 can also operate VCRs.

Outstanding Features

Authorized personnel may program the keypad and other Digiplex components through confidential access codes. Programmable components include CyberDomes®, PTZ receivers, matrix video switchers, and alarm interfaces. All data is stored in nonvolatile memory.

The KTD-400 keypad is housed in high impact, injection-molded plastic. The keypad is outfitted with low profile, easy-to-read keys and a backlit, liquid crystal display (LCD). It communicates with other Digiplex components through a RS422 signal over twisted-pair wire. It also offers a DTMF output for mini-matrix video switcher control.



Standard Features

- **Control for up to 512 PTZ sites**
- **Matrix switcher operation**
- **Multiplexer view/VCR control**
- **Mini-matrix control output**
- **Programmable nonvolatile memory**
- **Multispeed CyberDome control**
- **Twisted-pair control**
- **Liquid crystal display**
- **Compact and attractive keypad**
- **Injection-molded housing**
- **Rack-mount format available**

KTD-400

Controller Keypad

Specifications

Electrical

- Input voltage: 12 VDC
- Input power: 3.3 VA
- Input data signal: RS422
- Output data signal: RS422
- Output mini-matrix signal: DTMF, 1.25 V p-p typical on nominal 2 V pedestal

Control

- Momentary push buttons

Display

- 20 x 2 character liquid crystal display (LCD) with back lighting

Connection

- RJ45 modular phone jack

Mechanical

- Weight: 15.2 oz (431 g)
- Construction: High-impact, injection-molded ABS plastic
- Color: Gray

Related Diagram

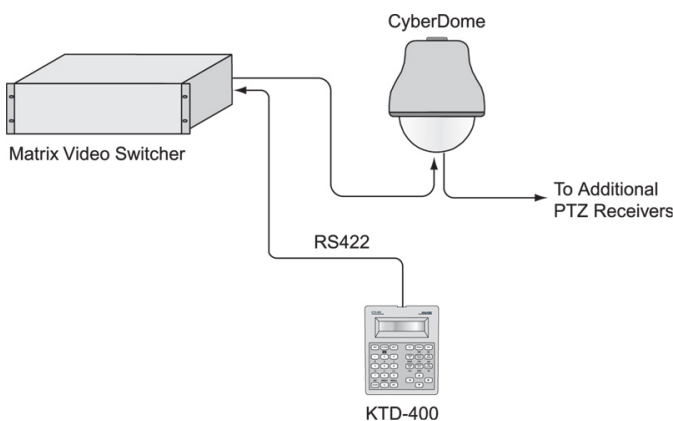

Ordering Information

KTD-400



Mailing Address
4575 Research Way, STE 250
Corvallis, OR 97333 USA
www.GESecurity.com

Americas
800-469-1676 (US only)
tel 541-754-9133
fax 541-754-7162

Asia
tel 852-2907-8108
fax 852-2142-5063
Australia
tel 61-3-9259-4700
fax 61-3-9259-4799

Europe
tel 32-2-725-11-20
fax 32-2-721-86-13
Latin America
tel 305-267-4301
fax 305-267-4300

www.GESecurity.com