

# GE Security

**SymVeo**, a fixed IP network color camera from GE Security, combines popular and effective XPosure image technology with digital network compatibility. SymVeo is well suited for surveillance, remote monitoring, and web-casting applications.

Designed specifically to meet the demand for a high-quality and affordable network camera, SymVeo uses XPosure technology to optimize the exposure for each pixel, showing details even in the shadows and highlights. Every detail can be captured accurately even in the most challenging lighting conditions, making it ideal for high risk applications like ATM locations and business and bank entrances.

SymVeo uses MPEG-4 compression for efficient distribution over a network. In addition, the camera incorporates "hybrid" technology from GE Security—it features both a digital output and an

analog output for local monitoring and recording. The high maximum frame-rate transmission of 30 frames per second at full D1 resolution (720 x 480) allows for smooth viewing of high-quality images.

SymVeo is equipped with a 100Base-TX/10Base-T (RJ-45) interface. Because the camera is designed to display images over the network, there is no limit on the number of users who can access and monitor the images of a single SymVeo camera.

SymVeo provides full D1 images with a maximum frame rate of 30 frames per second.

## Features

- Uses XPosure technology to produce detailed images even in challenging lighting conditions
- Fully networkable over 10/100 Base-T Ethernet
- Advanced MPEG-4 video compression
- "Hybrid" technology incorporates both digital and analog outputs
- Maximum frame rate of 30 frames per second at full D1 resolution

## SymVeo IP network camera





# Specifications

Americas  
503-885-5700  
888-GE-SECURITY  
(437-3287)  
faxback 800-483-2495  
info@gesecurity.com  
www.gesecurity.com

Asia  
tel 852-2907-8108  
fax 852-2142-5063

Australia  
tel 61-3-9259-4700  
fax 61-3-9259-4799

Europe  
tel 32-2-725-11-20  
fax 32-2-721-86-13

Latin America  
tel 305-593-4301  
fax 305-267-4300

## Features

- Image device: 1/3 in sensor with GE XPosure technology
- Dynamic range: 95 dB typical/120 dB maximum
- Scanning system: 525/60 lines (NTSC)
- Pixels: 720 (horizontal) x 540 (vertical)
- Resolution: 480 TVL (horizontal); 460 TVL (vertical)
- Sensitivity: 0.4 lux @ f1.2, 30 IRE
- Signal-to-noise ratio: 52 dB
- Color balance: ATW, ATW-WIDE, HOLD; range of 2,000 to 11,000 K
- Gain: AGC on/off
- Gamma correction: 0.45 (NTSC)
- Video output: Composite 1.0 V p-p at 75-ohm load
- Lens selection: Accepts manual or DC control lenses
- Lens mount: C and CS mounts

## Electrical

- Power source: Universal, 11 to 30 VDC
- Power consumption: 7 W minimum, 12 W recommended (12 VDC)

## Network

- Network protocols: TCP/IP
- Network line: 10/100Base-T Ethernet LAN
- Image resolution: D1 - 720x486
- Compression: MPEG-4
- Frame Rate: Maximum 30 frames per second (NTSC); 25 frames per second (PAL)

## Physical and Environmental

- Dimensions (HxWxD): 2.38 x 2.85 x 6.15 in. (60 x 72 x 156 mm)
- Weight: 21.5 oz (610 g)
- Operating temperature: 14° to 104°F (-10° to 40°C)

## Regulatory

- FCC, CE

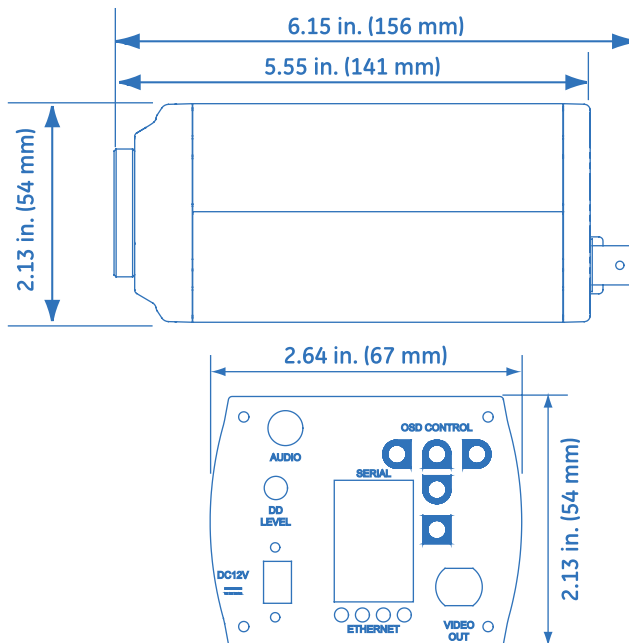

## Ordering information

SV-XP1 SymVeo IP color camera with XPosure technology, no lens or power supply included